

SINGER
991E3

SINGER 991 E3

Part numbers shown boxed indicate that they are assemblies, details of which may be found in the descriptions overleaf.

Grid references shown in brackets are component parts of assemblies

ACCESSORIES (NOT TO SCALE)

Supplied with Machine

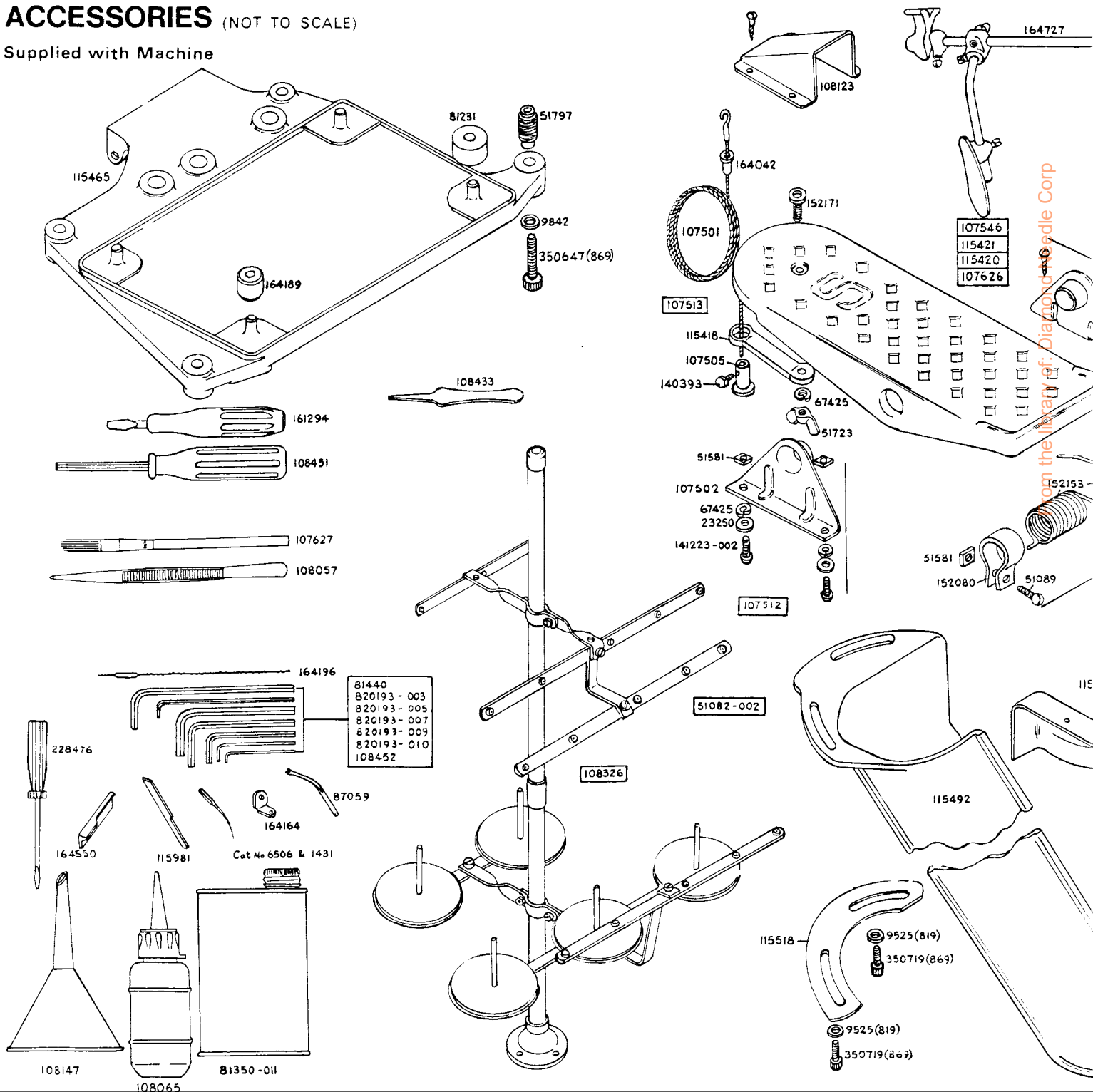

Available at an Extra Charge

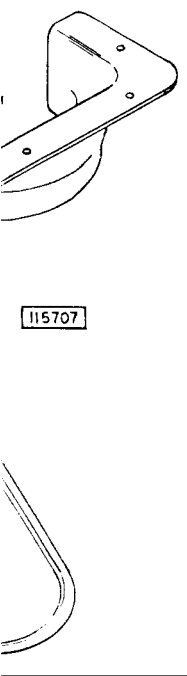
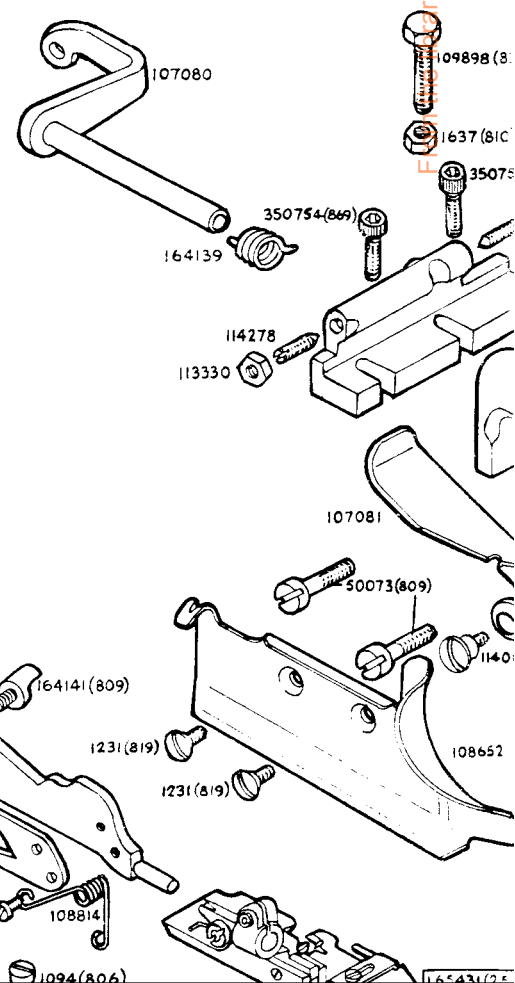
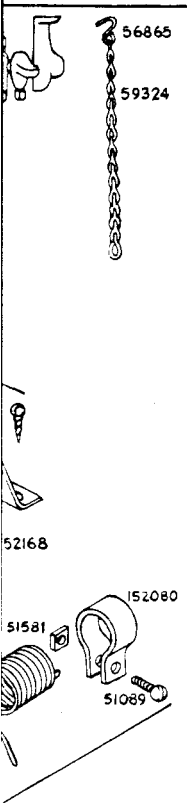
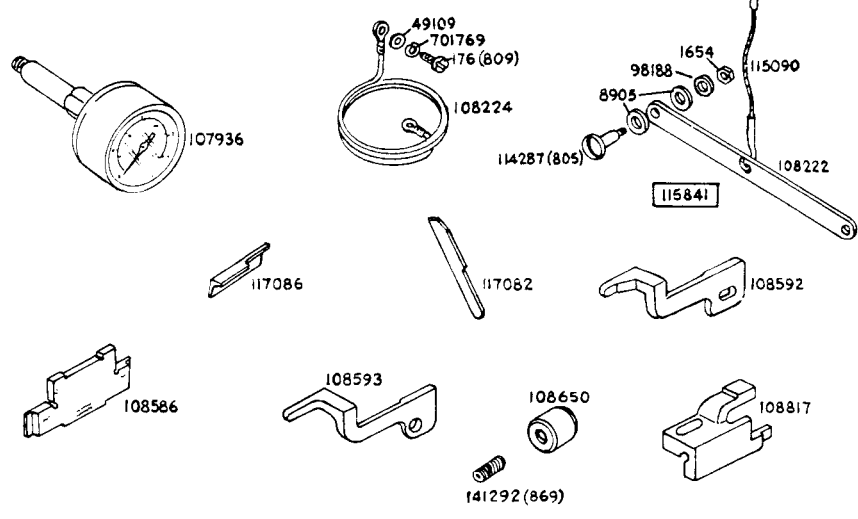

Copyright of: Diamond Needle Corp

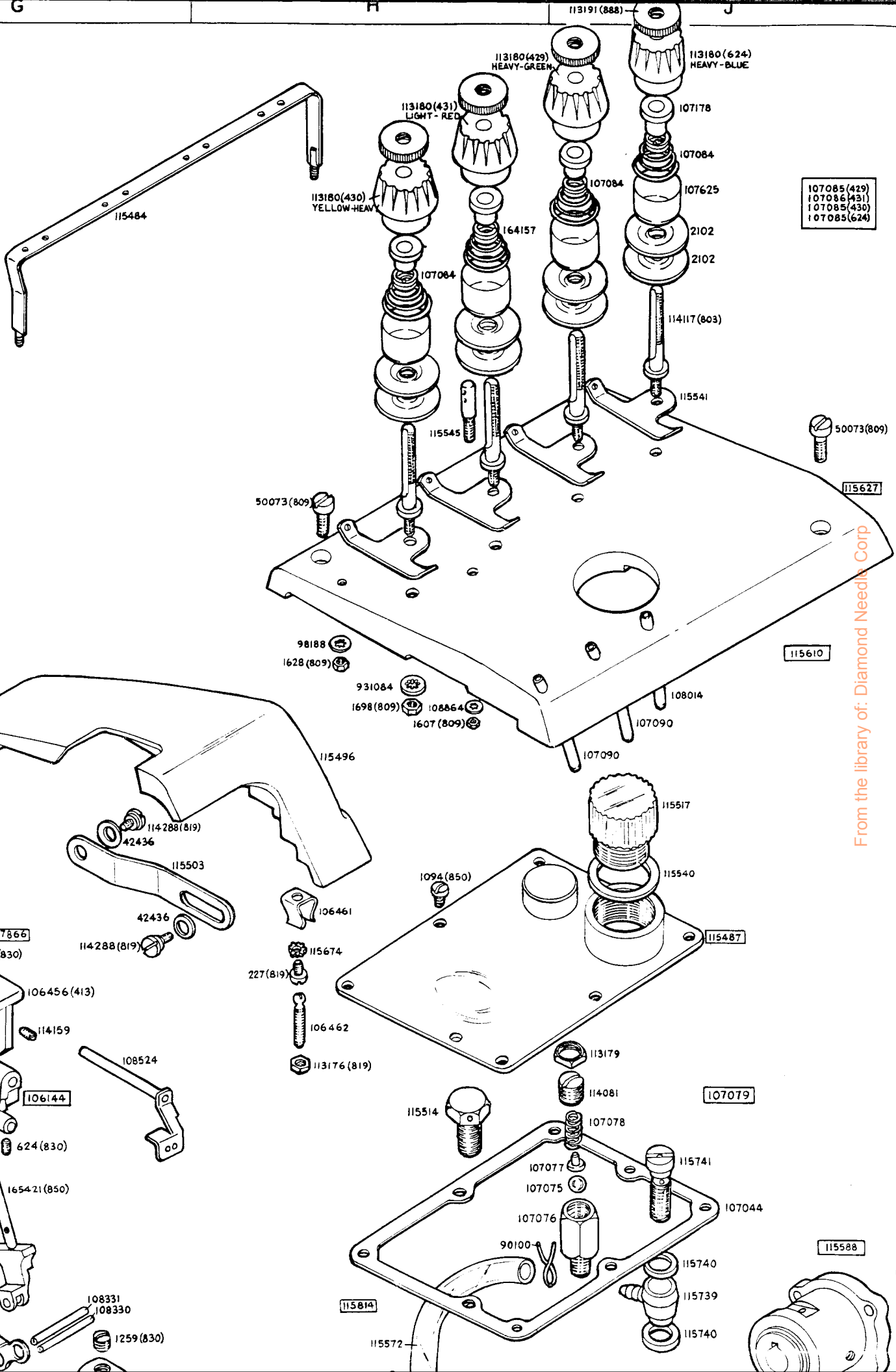

107085(429)
 107086(431)
 107085(430)
 107085(624)

From the library of: Diamond Needle Corp

CHAIN CUTTER RETRO-FIT KIT NUMBER 115071

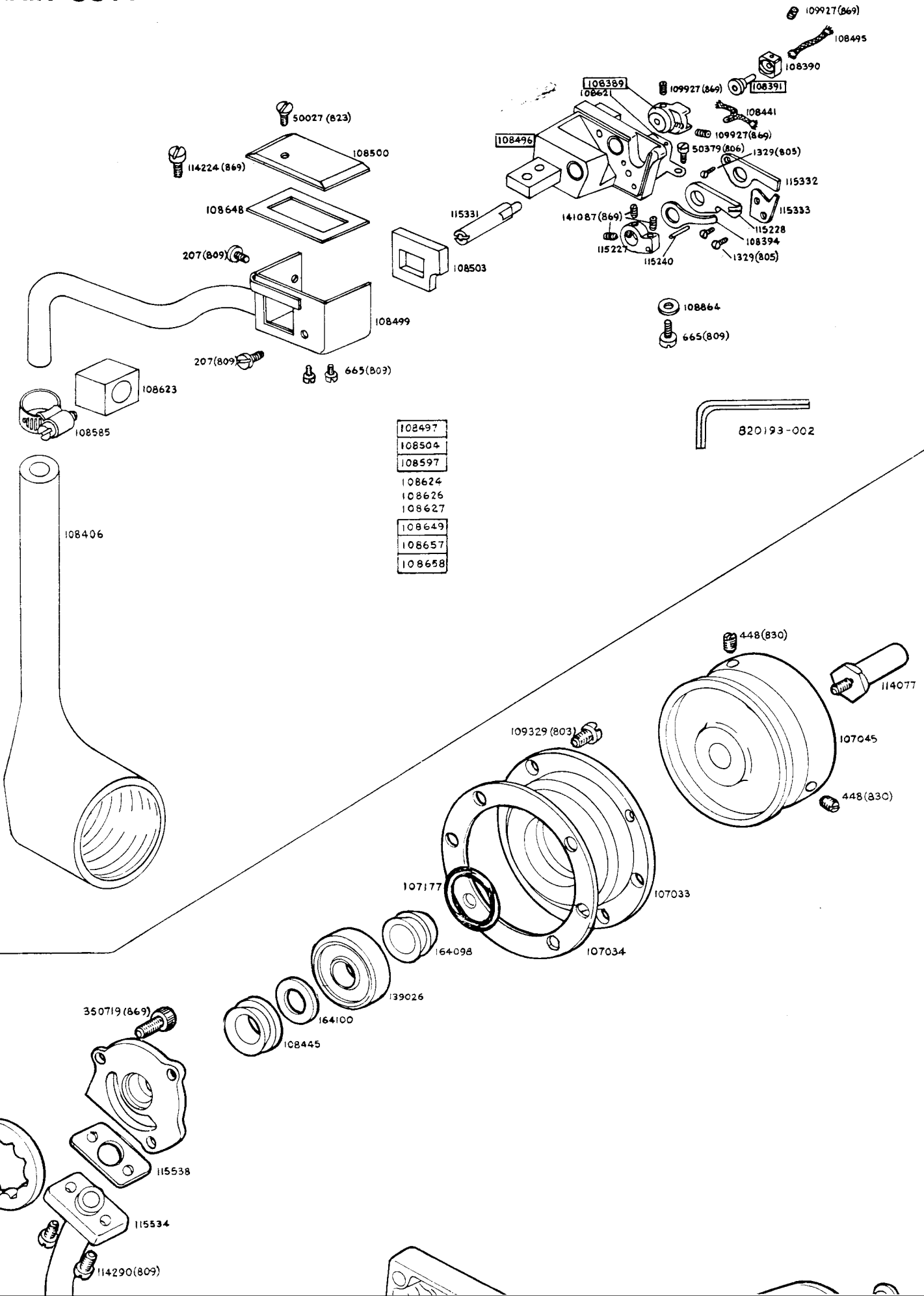

- | |
|--------|
| 108497 |
| 108504 |
| 108597 |
| 108624 |
| 108626 |
| 108627 |
| 108649 |
| 108657 |
| 108658 |

820193-002

From the library of: Diamond Needle Corp

1

2

3

4

5

6

7

8

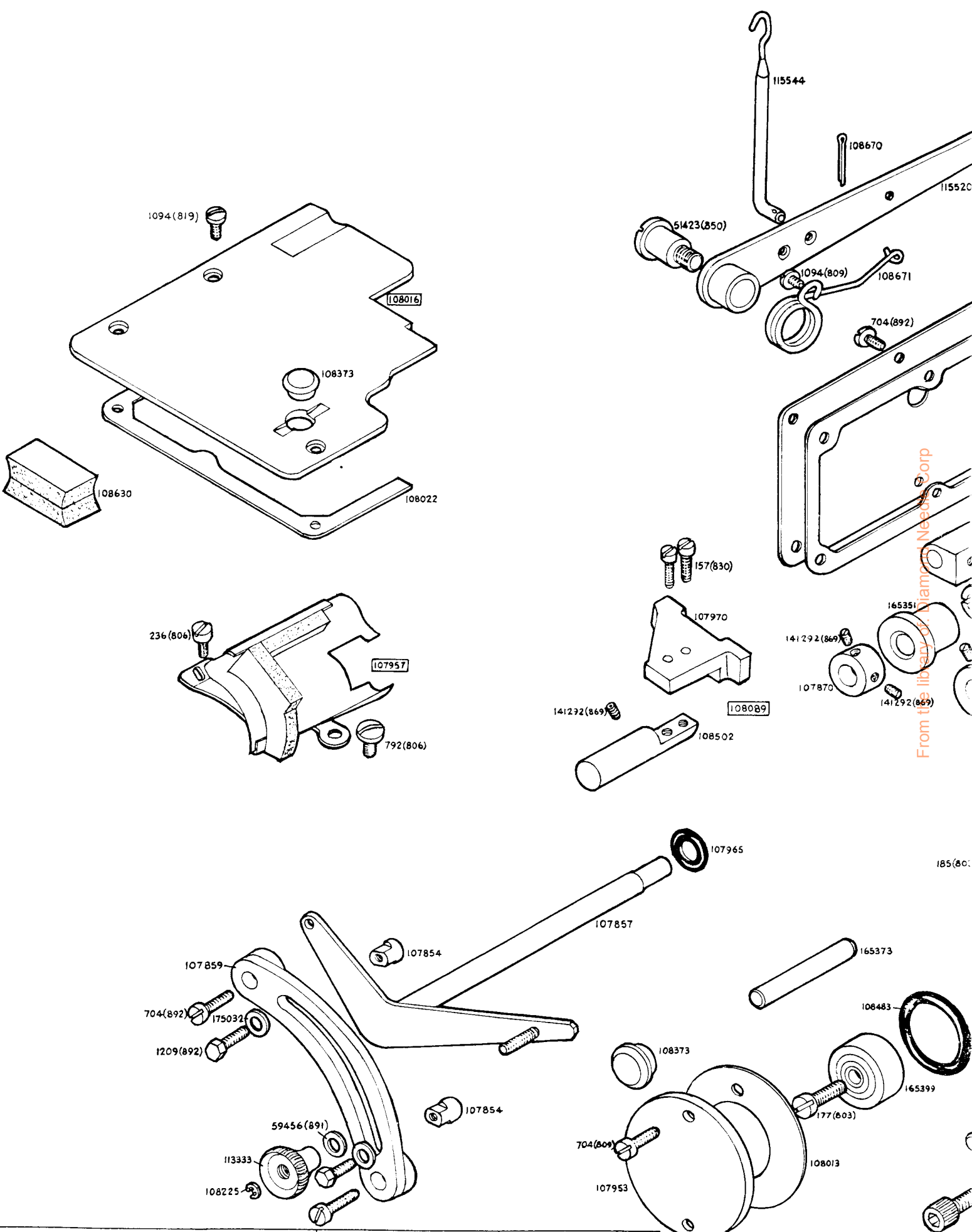

From the library of www.NeedleCorp.com

A

B

C

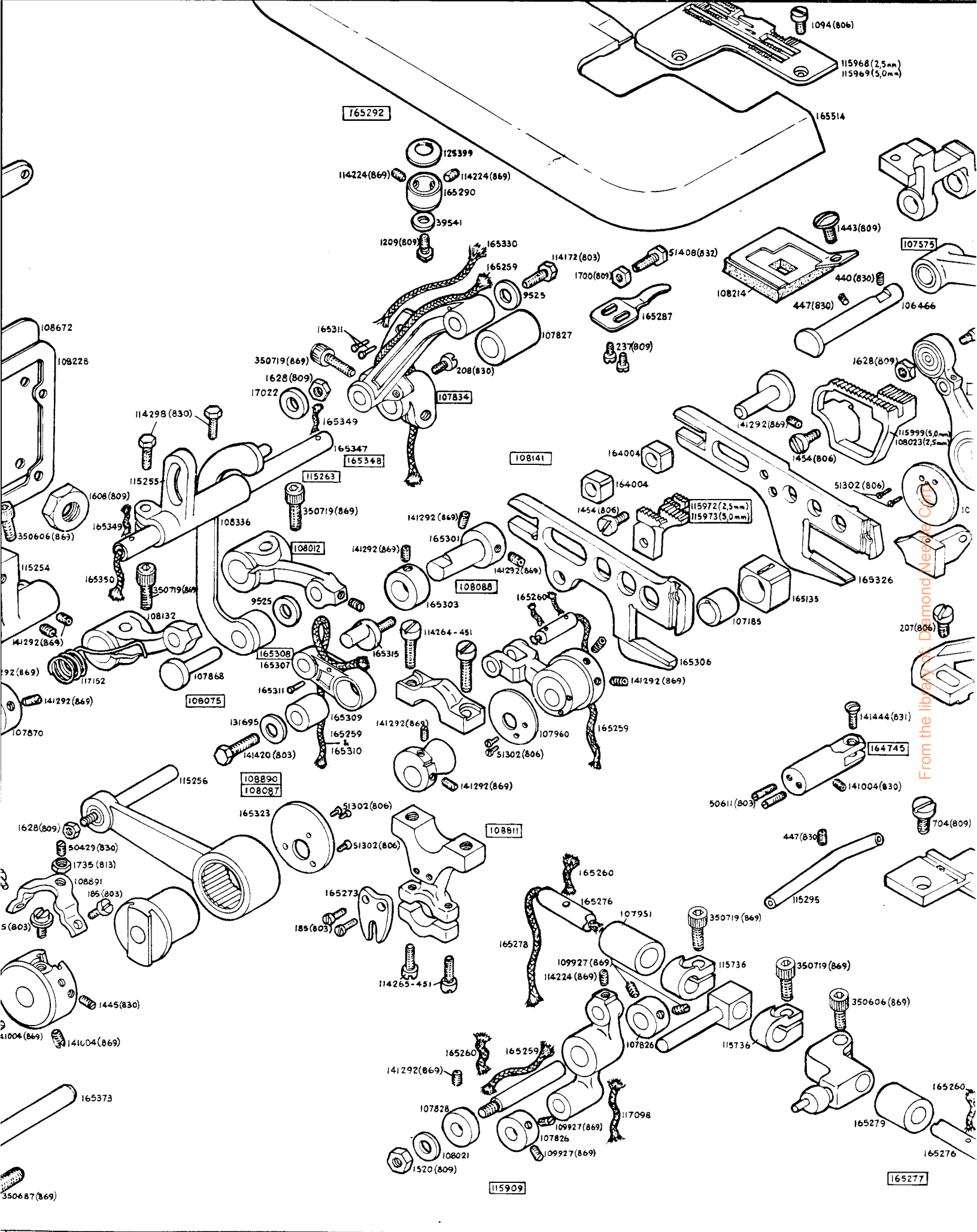

From the library: Diamond Needle Craft

D

E

F

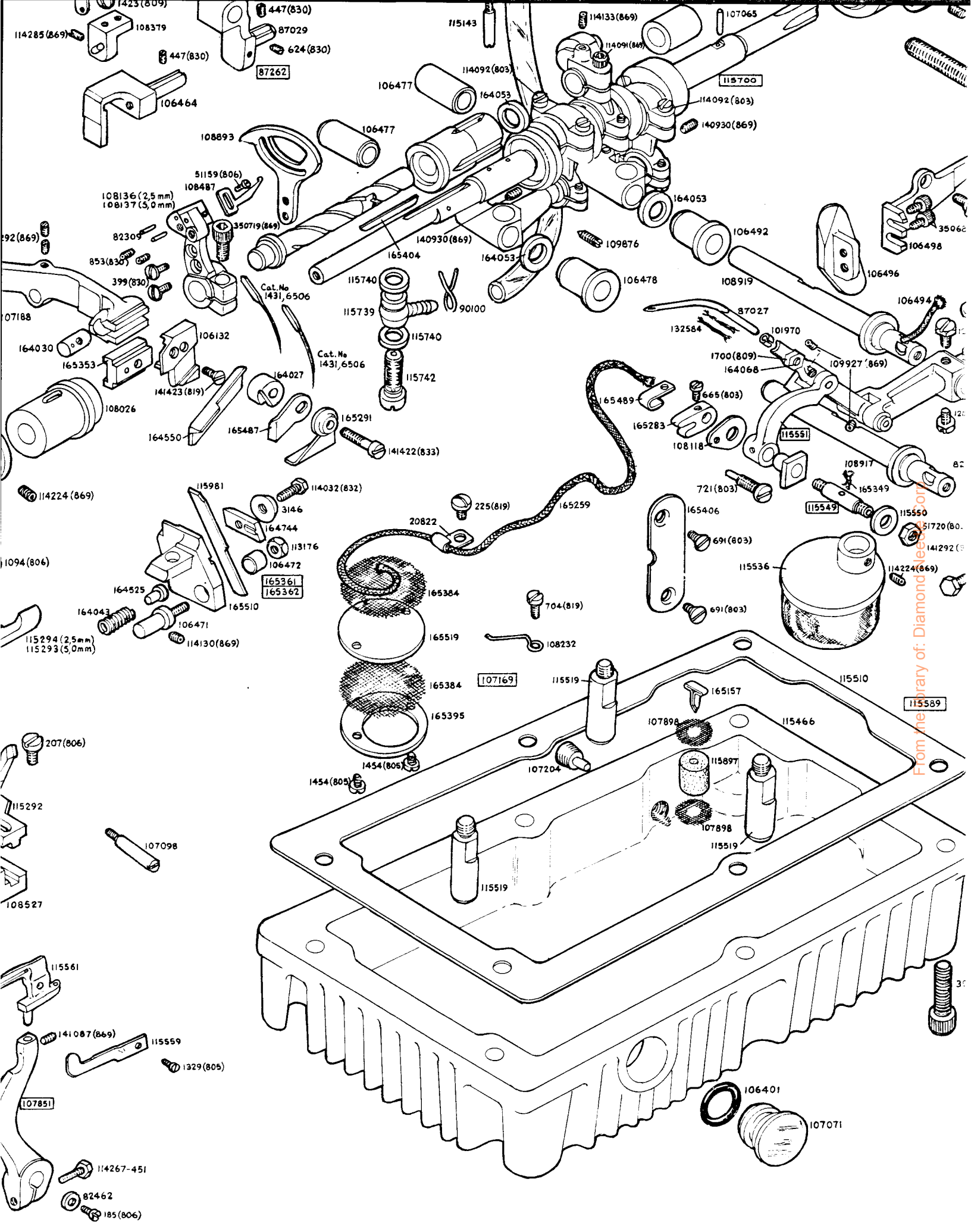

From the library of: Diamond Tools

G

H

J

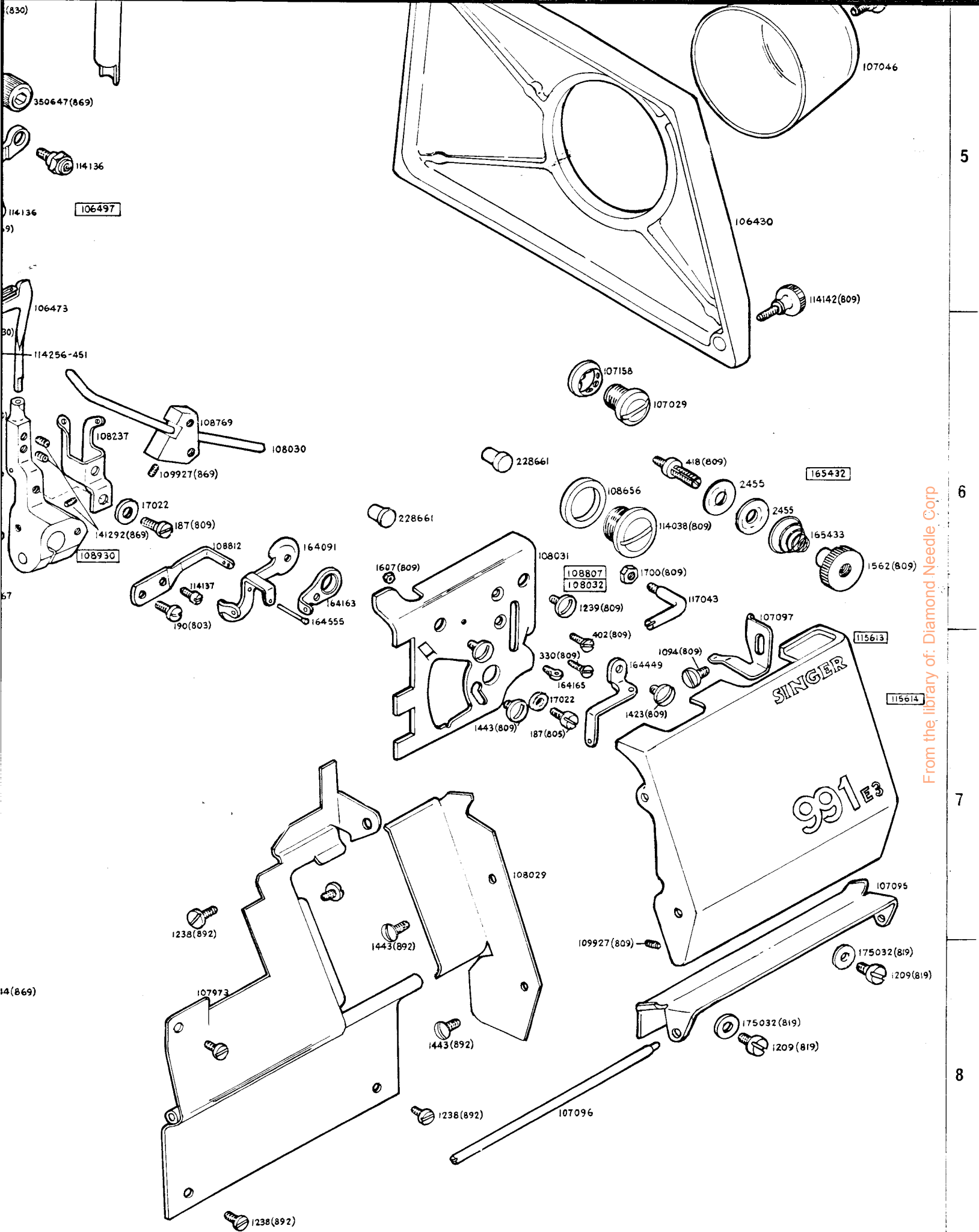

From the library of: Diamond Needle Corp

5

6

7

8

K

L

M

Part No.	Description	Grid Ref.
157(830)	Feed (back) Bar Guide Bracket Screw	C6
176(809)	Earthing Wire Screw	E2
177(803)	Machine Frame Rotary Shaft Extension Screw	C8
185(803)	Auxiliary Looper Driving Connection Locating Plate Screw	E7 E8
185(806)	Auxiliary Looper Shaft Screw	G8
185(803)	Feed Eccentric (adjustable) Stop Plate Screw	C7 B7
187(809)	Auxiliary Looper Thread Guide Securing Screw	K6
187(805)	Thread (looper right hand) or Spreader Take-up Screw	L7
207(806)	Needle Guard Screw (2)	F7 G7
207(809)	Chain Cutter Knife Holder and Feed Bar Guide Cover Securing Screw	K1 K2
208(830)	Feed (front) Bar Driving Arm Slide Block Plate Screw	E6
208(829)	Thread Eyelet (needle thread) Bridge Tube Support Securing Screw	G4
225(819)	Looper (right hand) or Spreader Carrier Connecting Link Adjusting Screw Pin Wick Clip Securing Screw	H6
227(819)	Knife (movable) Lever and Presser Bar (upright) Housing Cover Latch Spring Screw	H3
233(809)	Presser Foot Spring Screw	(F4)
233(850)	Chain Cutter Screw	F4
236(806)	Machine Frame Oil Splash Guard Securing Screw (upper)	A7
237(809)	Cloth Plate Lock Spring Screw	E6
330(809)	Thread (looper) Plate Thread Tube (long) Support Securing Screw (lower)	L7
356(803)	Knee Lifter Rock Shaft Knee Arm Hub Set Screw	(C2)
356(803)	Knee Lifter Rock Shaft Knee Plate Set Screw	(C2)
356(803)	Knee Lifter Rock Shaft Stop Dog Set Screw	(C2)
399(830)	Thread (needle) Controller Screw (2)	G5
402(809)	Thread (looper) Plate Thread Tube (long) Support Securing Screw (upper)	L7
418(809)	Tension (auxiliary looper) Screw Stud	M6
440(830)	Knife (movable) Lever Hinge Stud Set Screw (top)	F6
447(830)	Knife (movable) Lever Bearing Set Screw (long)	G5
447(830)	Knife (movable) Lever Guide Set Screw	G5
447(830)	Knife (movable) Lever Hinge Stud Set Screw (back)	F6
447(830)	Looper (left hand) Thread Tube (lower) Securing Screw	F7
448(830)	Machine Pulley Set Screw	M3
448(830)	Oil Pump Body Bushing and Machine Frame Rotary Shaft (intermediate) Bushing Set Screw	K5
460(830)	Thread Eyelet (needle thread) Set Screw	G3
462(830)	Presser Bar Lifting Bracket Set Screw (short)	G4
624(830)	Knife (movable) Lever Bearing Set Screw (short)	G5
624(830)	Presser Bar Lifting Bracket Set Screw (long)	G4
665(809)	Presser Foot Body Guide Plate Screw	(F4)
665(803)	Looper (right hand) or Spreader Carrier Connecting Link Adjusting Screw Pin Spring Clip Screw	J6
665(809)	Chain Cutter Knife Holder and Feed Bar Guide Cover Securing Screw (lower) (2)	L2
691(803)	Machine Frame Wearing Plate Screw (2)	J6
704(809)	Machine Frame Rotary Shaft Bearing (left) Cover Screw (2)	B8
704(809)	Needle Guard Holder Screw	F7
704(892)	Differential Feed Regulating Plate Securing Screw (2)	A8
704(892)	Machine Frame Closing Plate (rear) Screw (6)	C6
704(819)	Feed Driving Shaft Oil Wick Clip Securing Screw	H6
721(803)	Looper (right hand) or Spreader Carrier Connecting Link Adjusting Screw Pin Pivot Screw	J6
792(804)	Machine Frame Oil Splash Guard Securing Screw (lower)	B7
853(830)	Needle Set Screw	G5
1094(806)	Feed (front) Bar Wearing Plate Screw	F6
1094(819)	Thread (looper) Plate Cover Latch Spring Screw	M7
1094(850)	Machine Frame Top Cover Closing Plate Screw (8)	H3
1094(806)	Throat Plate Screw (2)	F5
1094(809)	Presser Bar Lifting Lever (long) Tension Spring Securing Screw	C6
1094(819)	Machine Frame Oil Splash Cover (top) Securing Screw (3)	A5
1100(830)	Feed (back) Dog Section (right) Screw	(F6)
1209(809)	Cloth Plate Hinge Stud Washer Retaining Screw	E5
1209(830)	Looper (right hand) or Spreader Driving Lever Clamping Screw	J6
1209(819)	Thread (looper) Plate Cover Hinge Bracket Screw (2)	M8
1209(892)	Differential Feed Regulating Lever Stop Screw	A8
1231(818)	Machine Frame Oil Splash Guard (top) Screw (2)	F4
1238(892)	Chip Guard (stationary) Screw (4)	K7 K8 L8
1239(809)	Thread (looper) Plate Screw (2)	L6
1259(830)	Knife (movable) Lever Bearing and Attachment Bracket Screw	G4
1329(805)	Auxiliary Needle Loop Spreader Screw	G8
1329(805)	Chain Cutter Knife (stationary) Extension Screw	M1
1329(805)	Chain Cutter Knife (stationary) Screw	M1
1423(809)	Thread Eyelet (needle thread) Bridge Securing Screw	G5
1423(809)	Thread (looper, right hand) or Spreader Thread Eyelet (movable) Screw	M7
1443(809)	Thread (looper, right hand) or Spreader Take-up Eyelet (adjustable) Screw	L7

Part No.	Description	Grid Ref.
1443(809)	Machine Frame Oil Splash Seal Support Securing Screw	F5
1443(892)	Chip Guard (movable) Screw (2)	L8
1445(830)	Feed Eccentric (adjustable) Slide Journal Locking Screw	D8
1454(806)	Feed Dog Screw	E6 F6
1454(805)	Machine Frame Oil Drain Plate Screw (2)	H7
1520(809)	Auxiliary Looper Avoid Driving Arm Hinge Stud Nut	E8
1520(809)	Thread Unwinder Mounting Tube Bracket Clamping Screw Nut (4)	(B4)
1520(809)	Thread Unwinder Spool Pin Nut (12)	(B4)
1520(809)	Thread Unwinder Spool Rest Support (lower rear) Securing Screw Nut	(B4)
1520(809)	Thread Unwinder Thread Eyelet Support Securing Screw Nut	(B4)
1562(809)	Tension (auxiliary looper) Regulating Thumb Nut	M6
1607(809)	Thread (looper, right hand) or Spreader Thread Eyelet (stationary) Nut	L6
1607(809)	Thread Needle Guide Post Securing Nut	H3
1608(809)	Presser Bar Lifting Lever (long) Hinge Stud Lock Nut	D6
1628(809)	Feed (back) Bar Driving Arm Eccentric Stud Nut	D6
1628(809)	Feed Driving Arm Pin Nut	D7
1628(809)	Knife (movable) Lever Hinge Pin Bearing Lock Nut	F6
1628(809)	Tension Thread Guide Securing Nut	H2
1637(810)	Presser Bar Lifting Lever Stop Screw Nut	F3
1654	Presser Bar Lifter Operating Arm Bracket Bolt Nut	E2
1698(809)	Tension Lock Nut	H3
1700(809)	Looper (right hand) or Spreader Locking Screw Stud Nut	J6
1700(809)	Presser Bar (swing-out) Lifting Screw Stud Nut	E4
1700(809)	Thread (looper) Plate Cover Latch Spring Pin Locking Nut	M6
1700(809)	Cloth Plate Position Bracket Screw Nut	E5
1735(813)	Feed Eccentric (adjustable) Stop Screw Nut	D7
2102	Tension Disc	H1 H2 J1
2455	Tension (auxiliary looper) Disc	M6
2763	Knee Lifter Rock Shaft	(C2)
2767	Knee Lifter Rock Shaft Knee Plate with 356(803)	(C2)
2770	Knee Lifter Rock Shaft Stop Dog with 356(803)	(C2)
3146	Knife (stationary) Clamping Gib Screw Washer	G6
6337	Knee Lifter Rock Shaft Lifting Bracket with two 140219(803)	(C2)
8905	Presser Bar Lifter Operating Arm Bracket Washer (2)	E2
9525	Differential Feed Driving Arm Stud Washer	D6
9525	Feed (front) Bar Connection Screw Washer	E5
9525(819)	Chip Chute Support Plate Screw Washer	C4
9842	Machine Base Mounting Screw Washer (4)	B2
12242	Knee Lifter Rock Shaft Hanger with two wood screws 1 inch No. 10	(C2)
17022	Auxiliary Looper Thread Guide Securing Screw Washer	K6
17022	Feed (back) Bar Driving Arm Eccentric Stud Nut Washer	D6
17022	Thread (looper, right hand) or Spreader Take-up Screw Washer	L7
20822	Looper (right hand) or Spreader Carrier Connecting Link Adjusting Screw Pin Wick Clip	H6
23250	Treadle Hinge Bracket Bolt Washer	B3
39541	Cloth Plate Hinge Stud Washer	E5
42436	Knife (movable) Lever and Presser Bar (upright) Housing Cover Stop Plate Screw Washer	G3
42436	Presser Bar (swing-out) Operating Lever Hinge Screw Washer	F4
49109	Earthing Wire Washer	E2
50027(823)	Chain Cutter Knife Holder and Feed Bar Guide Cover (top) Securing Screw	L1
50073(809)	Knife (movable) Lever and Presser Bar (upright) Housing Screw (2)	F4
50073(809)	Machine Frame Top Cover Screw (2)	H2 J2
50379(806)	Chain Cutter Knife Holder and Feed Bar Guide Oil Deflector Securing Screw (front)	M1
50429(830)	Feed Eccentric (adjustable) Stop Screw	D7
50611(803)	Knife (stationary) Holder Position Screw	F7
51082-002	Treadle Hinge Bracket Bolt 141223-002 with 51581	C3
51089	Treadle Position Collar Bolt with 51581	C3 D3
51145(803)	Feed Eccentric (adjustable) Slide Journal Adjusting Screw	D8
51159(806)	Thread (needle) Controller Adjuster Securing Screw	G5
51302(806)	Auxiliary Looper Avoid Eccentric End Washer Securing Screw	E7
51302(806)	Feed Eccentric (adjustable) End Washer Securing Screw	E7
51302(806)	Knife (movable) Eccentric End Washer Securing Screw (2)	F6
51362(830)	Presser Bar (swing-out) Pivot Screw Locking Plate Screw	E4
51408(832)	Cloth Plate Position Bracket Screw	E5
51423(850)	Presser Bar Lifting Lever (long) Hinge Stud	C5
51581	Treadle Position Collar Bolt Nut	C3 D3
51581	Treadle Hinge Bracket Bolt Nut	B3
51720	Looper (right hand) or Spreader Carrier Connecting Link Adjusting Screw Pin Nut	J6
51723	Treadle Extension Wing Nut	C3
51797	Machine Base Mounting Screw Insert (4)	B2
53663(803)	Presser Foot Extension (hinged) Screw Nut	(F4)

From the library of: Diametric Needle Corp

Part No.	Description	Grid Ref.
5885	Chain Hook (small)	D2
9324	Chain (8 inch long) with 5885	D2
9458(891)	Differential Feed Regulating Lever Thumb Nut Washer	A8
7425	Treadle Extension Wing Nut Lock Washer	C3
7425	Treadle Hinge Bracket Bolt Nut Lock Washer	B3
7231	Machine Cushion (large) (2)	B2
350-011	Tin of Oil (500ml Type H)	A4
7440	Wrench (short) for 1/16 inch Socket Head Screw	—
2309	Looper (left hand) Stop Pin	K6
2309	Needle Stop Pin	G5
2462	Auxiliary Looper Shaft Screw Washer	G8
7027	Looper (right hand)	J6
7029	Knife (movable) Lever Bearing and Attachment Bracket	G5
7058	Spreader (for N.A.I.P.D.)	B4
7262	Knife (movable) Lever Bearing and Attachment Bracket 87029 with 1259(830)	G5
0100	Oil Pipe Retaining Clip	H5 J4
8188	Tension Thread Guide Securing Nut Washer	H2
8188	Presser Bar Lifter Operating Arm Bracket Bolt Washer	E2
9300	Machine Frame Rotary Shaft Ball Sleeve Guide	—
01970	Looper (right hand) or Spreader Position Collar	J6
06132	Knife (movable) Holder	G6
06144	Presser Bar Lifting Bracket with 462(830) and 624(830)	G4
06401	Oil Reservoir Oil Sight Gauge Seal (O-ring)	J8
06430-451	Belt Cover	M5
06456(696)	Knife (movable) Lever and Presser Bar (upright) Housing with 460	G3
06461	Knife (movable) Lever and Presser Bar (upright) Housing Cover Latch Spring	H3
06462	Knife (movable) Lever and Presser Bar (upright) Housing Cover Latch Spring Pin	H3
06464	Knife (movable) Lever Guide	G5
06466	Knife (movable) Lever Hinge Stud	F6
06471	Knife (stationary) Holder Sleeve Stud	G7
06472	Knife (stationary) Holder Sleeve	G6
06473	Looper (left hand)	K6
06476	Looper (right hand) or Spreader Driving Shaft Access Hole Plug	—
06477	Looper (left hand) Driving Shaft Bushing (back)	H5
06477	Looper (right hand) or Spreader Driving Shaft Bushing (back)	H5
06478	Looper (left hand) Driving Shaft Bushing (front)	H5
06492	Looper (right hand) or Spreader Driving Shaft Bushing (front)	J5
06494	Looper (right hand) or Spreader Driving Shaft Oil Wick	J6
06496	Looper (right hand) or Spreader Four-Bar Linkage Mechanism Stabiliser	J5
06497	Looper (right hand) or Spreader Four-Bar Linkage Mechanism Stabiliser 106496 with 106498 and two 350680(869)	J5
06498	Looper (right hand) or Spreader Four-Bar Linkage Mechanism Stabiliser Support Bracket	J5
07029	Machine Frame Oil Pressure Gauge Connection Plug	M6
07033	Machine Frame Rotary Shaft Ball Bearing Housing	L3
07034	Machine Frame Rotary Shaft Ball Bearing Housing Gasket	L3
07037	Machine Frame Rotary Shaft Oil Metering Pin	—
07044	Machine Frame Top Cover Closing Plate Gasket	J4
07045	Machine Pulley with two 448(830)	M3
07046	Machine Pulley Cap	M5
07055	Needle Driving Shaft Crank Connection Roller (27)	—
07065	Oil Pump Drive Pin	J5
07066	Oil Pump Rotor (inner)	K4
07067	Oil Pump Rotor (outer)	K4
07071	Oil Reservoir Oil Sight Gauge	J8
07075	Oil Pump Relief Valve	J4
07076	Oil Pump Relief Valve Body	J4
07077	Oil Pump Relief Valve Plunger	J4
07078	Oil Pump Relief Valve Spring	J4
07079	Oil Pump Relief Valve, complete, Nos. 107075, 107076, 107077 107078, 113179 and 114081	J4
07080	Presser Bar Lifting Lever	F3
07081	Presser Bar (swing-out) Opening Lever	F4
07084	Tension (heavy) Spring	H1 J1
07085(429)	Tension (heavy), complete, (green) Nos. 107084, 107178, 107625, 113180(429), 113191(888), 114117(803) and two 2102 (for agents only)	J1
07085(430)	Tension (heavy), complete, (yellow) Nos. 107084, 107178, 107625 113180(430), 113191(888), 114117(803) and two 2102 (for agents only)	J1
07085(624)	Tension (heavy), complete, (blue) Nos. 107084, 107178, 107625, 113180(624), 113191(888), 114117(830) and two 2102 (for agents only)	J1
07086(431)	Tension (light), complete, (red) Nos. 107178, 107625, 113180(431), 113191(888), 114117(803), 164157 and two 2102 (for agents only)	J1
07090	Looper (left hand) Thread Tube (upper)	J3

Part No.	Description	Grid Ref.
107090	Thread (looper, right hand) or Spreader Tube (upper)	J3
107095	Thread (looper) Plate Cover Hinge Bracket	M7
107096	Thread (looper) Plate Cover Hinge Pin	L8
107097	Thread (looper) Plate Cover Latch Spring	M7
107098	Cloth Plate Lock Spring Retaining Screw Stud	G7
107158	Machine Frame Oil Pressure Gauge Connection Plug Gasket	L6
107181	Presser Bar Bracket	F5
107189	Oil Return Filter (front) complete, with 107898 (for agents only)	H7
107177	Machine Frame Rotary Shaft Ball Bearing Retaining Ring	L3
107178	Tension Spring Bushing	J1
107185	Feed Lifting Eccentric	F6
107188	Knife (movable) Lever Hinge Pin	G6
107204	Oil Reservoir Drain Plug	H7
107501	Operating Cable	B2
107502	Treadle Hinge Bracket	C3
107505	Operating Cable Retaining Collar with 140393	B3
107512	Treadle Hinge Bracket 107502 with two each 23250, 51082-002 and 67452	C3
107513	Operating Cable, complete, Nos. 107501 and 107505	B2
107546	Treadle 115420 with two 107502, four each 23250, 51082-002 and 67425	C2
107575	Knife (movable) Lever with two 141292(869)	F5
107825	Tension Spring Cover	H1 J1
107826	Treadle 115420 with two 107502 and four wood screws 3/4 inch (19 mm) No. 12 R.H.	C2
107827	Lint Cleaning Brush	A3
107826	Auxiliary Looper Avoid Driving Arm Retaining Collar with two 109927(869)	E8
107826	Auxiliary Looper Avoid Driving Arm Slide Block Collar with two 109927(869)	E8
107827	Feed Driving Shaft Bushing (right)	E6
107828	Auxiliary Looper Avoid Driving Arm Thrust Washer	E8
107829	Feed (front) Bar Wearing Plate	F6
107832	Knife (movable) Lifting Lever with 108213 and two 51302(806)	F6
107834	Feed (front) Bar Connection with 165259, 165330 and two 165311	E6
107851	Auxiliary Looper Carrier with 114267-451 and 141087(889)	G8
107854	Differential Feed Regulating Lever Stop	B8
107857	Differential Feed Regulating Lever	B8
107859	Differential Feed Regulating Plate	A8
107866	Knife (movable) Lever and Presser Bar (upright) Housing, complete, Nos. 42436, 106144, 106456(696), 107080, 107081, 108524, 114159, 114275(888), 114288(819), 164139, 164416 and 165421	—
107888	Differential Feed Driving Arm Stud	D7
107870	Differential Feed Regulating Lever Shaft Collar with two 141292(869)	C7
107870	Feed Driving Shaft Position Collar with two 141292(869)	C7
107898	Oil Return Filter Screen	J7
107936	Oil Pressure Gauge	D2
107950	Feed (back) Dog (2.5 mm) Section (right)	(F6)
107950	Feed (back) Dog (5 mm) Section (right)	(F6)
107951	Auxiliary Looper Shaft Bushing (rear)	E8
107953	Machine Frame Rotary Shaft Bearing (left) Cover	B8
107957	Machine Frame Oil Splash Guard	B7
107960	Auxiliary Looper Avoid Eccentric End Washer	E7
107965	Differential Feed Regulating Lever Shaft Oil Ring	C7
107970	Feed (back) Bar Guide Bracket	C7
107973	Chip Guard (stationary)	K8
108012	Differential Feed Driving Arm with 350719(869) and 141292(869)	D6
108013	Machine Frame Rotary Shaft Bearing (left) Cover Gasket	C8
108014	Thread (auxiliary looper) Tube (upper)	J2
108016	Machine Frame Oil Splash Cover (top) with 108022	B6
108021	Auxiliary Looper Avoid Driving Arm Hinge Stud Securing Nut Washer	E8
108021	Looper (right hand) or Spreader Carrier Connecting Link Washer	—
108022	Machine Frame Oil Splash Cover (top) Gasket	B6
108023	Feed (front) Dog (2.5 mm)	F6
108026	Machine Frame Rotary Shaft Bushing (front)	G6
108029	Chip Guard (movable)	L7
108030	Thread (looper) Plate Thread Tube (long)	K6
108031	Thread (looper) Plate	L6
108032	Thread (looper) Plate 108031 with 330(809), 402(809), 1607(809), 108030, 102769, 164163, 164165, 164449, 1423(809) & 1443(809)	L6
108057	Tweezers	A3
108058	Dust Cover	—
108065	Oil Dispenser	A4
108075	Differential Feed Driving Arm 108012 with 9525 and 107868	D7
108087	Feed Eccentric (adjustable) with 165323 and two 51302(806)	D7
108088	Feed Bar Hinge Pin (eccentric) 165301 with 165303 and two 164004	E6
108089	Feed (back) Bar Guide Bracket 107970 with 108502 & two 157(830)	C7

Part No. of: Differential Feed

Part No.	Description	Grid Ref.
08118	Looper (right hand) or Spreader Carrier Connecting Link Stop Nut Oil Seal	J6
08123	Belt Cover (rear)	C2
08132	Differential Feed Regulating Lever Return Spring Arm with 350719(869)	D7
08136	Needle Carrier (2.5 mm) with two 82309	G5
08137	Needle Carrier (5 mm) with two 82309	G5
08141	Feed (back) and (front) Bars, complete, Nos. 108088 and 165135	E6
08147	Oil Funnel	A4
08213	Knife (movable) Eccentric End Washer	F8
08214	Machine Frame Oil Splash Seal Support	F5
08222	Presser Bar Lifter Operating Arm	E2
08224	Earthing Wire	E2
08225	Differential Feed Regulating Lever Thumb Nut Retainer	A8
08228	Machine Frame Closing Plate (rear) Gasket	D6
08232	Feed Driving Shaft Oil Wick Clip	H7
08237	Auxiliary Looper Thread Guide	K6
08311	Thread Unwinder Spool Pin (5)	(B4)
08312	Thread Unwinder Spool Rest (5)	(B4)
08314	Thread Unwinder Spool Rest Support (lower rear)	(B4)
08315	Thread Unwinder Spool Rest Support (lower front)	(B4)
08318	Thread Unwinder Mounting Tube End Plug	(B4)
08320	Thread Unwinder Mounting Tube Bracket (4)	(B4)
08321	Thread Unwinder Thread Guide Holder	(B4)
08322	Thread Unwinder Thread Eyelet (21)	(B4)
08323	Thread Unwinder Mounting Tube	(B4)
08324	Thread Unwinder Thread Eyelet Support (upper front) with six 108322 and 117008	(B4)
08324	Thread Unwinder Thread Guide with six 108322 and 117008	(B4)
08325	Thread Unwinder Thread Eyelet Support (upper rear) with three 108322 and 117008	(B4)
08326	Thread Unwinder (five spools), complete, Nos. 108314, 108315, 108318, 108323, 108325, two 108321, three 108324, four 108320, five each 108311, 108312, 150203, nine 114097(809), twenty-one 1520(809), four wood screws 1 1/4 inch No. 12 R.H.	B4
08329	Thread Eyelet (needle thread) Bridge	G4
08330	Thread Eyelet (needle thread) Bridge Tube (long)	G4
08331	Thread Eyelet (needle thread) Bridge Tube (short)	G4
08336	Differential Feed Driving Arm Connecting Link, complete	D6
08373	Machine Frame End Cover Hole Plug	B8
08373	Machine Frame Oil Splash Cover (top) Access Plug	A6
08379	Thread Eyelet (needle thread) Bridge Tube Support with 114285(869)	G5
08380	Thread Eyelet (needle thread) Bridge 108329 with 108330, 108331, 108379 and two 208(829)	G4
08381	Chain Cutter	F4
08389	Chain Cutter Knife (movable) Driving Fork with two 109927(869)	M1
08390	Chain Cutter Knife (movable) Driving Slide Block	M1
08391	Chain Cutter Knife (movable) Driving Slide Block Stud with 108495	M1
08394	Chain Cutter Knife (movable) Spring	M1
08406	Chain Cutter Suction Pipe	K2
08433	Feeler Gauge	B3
08441	Chain Cutter Knives Oil Wick	M1
08445	Oil Pump Cover Oil Seal	L4
08451	Wrench (plastic handle) for 5/64 inch Socket Head Screw	A3
08452	Wrench (long) for 5/32 inch Socket Head Screw	A3
08483	Machine Frame Rotary Shaft Bearing (left) Retaining Ring	C8
08487	Thread (needle) Controller Adjuster	G5
08495	Chain Cutter Knife (movable) Driving Slide Block Stud Wick	M1
08496	Chain Cutter Knife Holder and Feed Bar Guide with 108621	L1
08497	Chain Cutter Assembly, Nos. 50027(823), 108394, 108441, 108496, 108499, 108503, 108597, 108623, 115227, 115240, 115331, 115332, 115333, two each 207(809), 865(809) and three 1329(805)	L2
08499	Chain Cutter Knife Holder and Feed Bar Guide Cover	L2
08500	Chain Cutter Knife Holder and Feed Bar Guide Cover (top)	L1
08502	Feed (back) Bar Guide Pin	C7
08503	Chain Cutter Knife Holder and Feed Bar Guide Cover Seal (inner)	L1
08504	Machine Frame Oil Splash Cover with 108022	L2
08524	Thread Eyelet (needle thread)	G4
08527	Needle Guard Holder	F7
08585	Chain Cutter Suction Pipe Clip	K2
08586	Looper (right hand) and Needle Carrier Height Gauge	D2
08592	Looper (left hand) Setting Gauge	E2
08593	Auxiliary Looper Gauge	E2
08597	Chain Cutter Knife (movable) Driving Fork 108389 with 108390 and 108391	L2
08621	Chain Cutter Knife Holder and Feed Bar Guide Oil Deflector	M1
08623	Chain Cutter Knife Holder and Feed Bar Guide Cover Suction Tube Oil Seal	K2

Part No.	Description	Grid Ref.
108624	Cloth Plate	L2
108626	Machine Frame Oil Splash Guard	L2
108627	Machine Frame Oil Splash Seal Support	L2
108630	Machine Frame Oil Seal	A6
108648	Chain Cutter Knife Holder and Feed Bar Guide Cover (top) Gasket	L1
108649	Cloth Plate, complete, Nos. 1700(809), 51408(832), 108624, 165287 and two 237(809)	L2
108650	Auxiliary Looper Shaft (positioning) Gauge	E2
108652	Machine Frame Oil Splash Guard (top)	F4
108654	Feed (back) Dog Section (left) (2.5 mm)	(L2)
108655	Feed (back) Dog Section (left) (5 mm)	(L2)
108656	Oil Pump Body Clamping Screw Hole Plug Screw Gasket	L6
108657	Feed (back) Dog (2.5 mm), complete, Nos. 1100(830), 107950 and 108654	L2
108658	Feed (back) Dog (5 mm), complete, Nos. 1100(830), 107950 and 108655	L2
108670	Presser Bar Lifting Lever (long) Connection Rod Cotter Pin	C5
108671	Presser Bar Lifting Lever (long) Tension Spring	C6
108672	Machine Frame Closing Plate (rear)	D6
108769	Thread (looper) Plate Thread Tube (long) Support with 109927(869)	K6
108807	Thread (looper) Plate 108031 with 330(809), 402(809), 108030 and 108769 (for agents only)	L6
108811	Auxiliary Looper Driving Connection with 165273 and two 185(803)	E7
108812	Thread (looper) Take-up	K6
108814	Presser Foot Spring	F4
108817	Auxiliary Looper Timing Gauge	E2
108864	Thread Needle Guide Post Securing Nut Washer	H3
108890	Feed Eccentric (adjustable) and Stop Plate, complete, Nos. 108087, 108891 and two 185(803)	O7
108891	Feed Eccentric (adjustable) Stop Plate with 1735(813) and 50429(830)	D7
108893	Thread (needle) Controller	G5
108917	Looper (left hand) Driving Shaft	J6
108919	Looper (right hand) or Spreader Driving Shaft with 106494	J5
108930	Looper (left hand) Carrier with 82309, 114267-451 and four 141292(869)	K6
109329(803)	Machine Frame Rotary Shaft Ball Bearing Housing Screw (4)	L3
109876	Needle Driving Shaft Bushing Locating Screw	H5
109898(832)	Presser Bar Lifting Lever Stop Screw	F3
109927(869)	Auxiliary Looper Avoid Driving Arm Retaining Collar Set Screw	E8
109927(869)	Auxiliary Looper Avoid Driving Arm Slide Block Collar Set Screw	E8
109927(869)	Looper (right hand) or Spreader Carrier Connecting Link Hinge Pin Set Screw	J6
109927(869)	Thread (looper) Plate Cover Hinge Pin Locking Screw	M8
109927(869)	Thread (looper) Plate Thread Tube (long) Securing Screw	K6
109927(869)	Chain Cutter Knife (movable) Driving Fork Set Screw	M1
109927(869)	Chain Cutter Knife (movable) Driving Slide Block Stud Set Screw	M1
113176(850)	Knife (stationary) Holder Sleeve Stud Lock Nut	G6
113176(850)	Knife (movable) Lever and Presser Bar (upright) Housing Cover Spring Pin Lock Nut	H4
113179	Oil Pump Relief Valve Spring Screw Stud Locking Nut	J4
113180(429)	Tension (heavy) Regulating Thumb Nut (green)	J1
113180(431)	Tension (light) Regulating Thumb Nut (red)	H1
113180(430)	Tension (heavy) Regulating Thumb Nut (yellow)	H1
113180(624)	Tension (heavy) Regulating Thumb Nut (blue)	J1
113191(888)	Tension (heavy) Regulating Thumb Nut Lock Nut	H1 J1
113191(888)	Tension (light) Regulating Thumb Nut Lock Nut	H1
113330(809)	Knife (movable) Lever and Presser Bar (upright) Housing Cover Hinge Bracket Centre Screw Lock Nut	F3
113333	Differential Feed Regulating Lever Thumb Nut	A8
114032(832)	Knife (stationary) Clamping Gib Screw	G6
114038(809)	Oil Pump Body Clamping Screw Hole Plug Screw	M6
114077	Machine Frame Rotary Shaft Screw Stud	M3
114081	Oil Pump Relief Valve Spring Screw Stud	J4
114082	Presser Bar (swing-out) Opening Lever Hinge Screw	F4
114091(869)	Needle Driving Shaft Crank Clamping Screw	H5
114092(803)	Looper (left hand) Driving Shaft Crank Clamping Screw	H5
114092(803)	Looper (right hand) or Spreader Driving Shaft Crank Clamping Screw	J5
114097(809)	Thread Unwinder Mounting Tube Bracket Clamping Screw (4)	(B4)
114097(809)	Thread Unwinder Spool Rest Support (lower rear) Securing Screw	(B4)
114097(809)	Thread Unwinder Thread Eyelet Support Securing Screw	(B4)
114097(809)	Thread Unwinder Thread Guide Holder Screw	(B4)
114117(803)	Tension Screw Stud	H2 J1
114130	Knife (stationary) Holder Sleeve Stud Set Screw	G7
114133(869)	Needle Driving Shaft Crank Position Screw	H5
114136	Looper (right hand) or Spreader Four-Bar Linkage Mechanism Stabiliser Securing Screw (2)	J5
114137(803)	Thread (looper) Take-up Screw	K6

Part No.	Description	Grid Ref.
114142(809)	Belt Cover Screw (2)	M5
114159	Pressure Regulating Thumb Screw Lock Screw	G3
114172(803)	Feed (front) Bar Connection Screw	E5
114224(869)	Auxiliary Looper Avoid Driving Arm Set Screw	E8
114224(869)	Cloth Plate Position Collar Set Screw	E5
114224(869)	Knife (movable) Eccentric Set Screw	G6
114224(869)	Oil Pump Suction Filter Collar Securing Screw	J6
114224(869)	Chain Cutter Knife Holder and Feed Bar Guide Pin Securing Screw	K1
114256-451	Looper (right hand) or Spreader Driving Lever Clamping Screw	K6
114258-451	Looper (left hand) Driving Shaft Crank Connection Cap (upper) Screw	—
114258-451	Looper (right hand) or Spreader Driving Shaft Crank Connection Cap (upper) Screw	—
114263-451	Looper (left hand) Driving Shaft Crank Connection Cap (lower) Screw	—
114263-451	Looper (right hand) or Spreader Driving Shaft Crank Connection Cap (lower) Screw	—
114264-451	Auxiliary Looper Driving Connection Screw (upper)	E7
114264-451	Needle Driving Shaft Crank Connection Cap (lower) Screw (2)	—
114265-451	Auxiliary Looper Driving Connection Screw (lower)	E8
114267-451	Auxiliary Looper Carrier Clamping Screw	G8
114267-451	Looper (left hand) Carrier Clamping Screw	K6
114275(888)	Pressure Regulating Thumb Screw	G3
114278(803)	Knife (movable) Lever and Presser Bar (upright) Housing Cover Hinge Bracket Centre Screw	F3
114285(869)	Thread Eyelet (needle thread) Bridge Tube Securing Screw	G5
114287(805)	Presser Bar Lifter Operating Arm Bracket Bolt	E2
114288(819)	Knife (movable) Lever and Presser Bar (upright) Housing Cover Stop Plate Screw	G3
114290(809)	Oil Pump Suction Pipe Securing Screw	K4
114292(869)	Machine Frame Hole Plug Screw	—
114298(830)	Feed (back) Bar Driving Arm Clamping Screw	D6
115071	Retro-fit Chain Cutter Kit, complete, Nos. 50379(806), 108497, 108504, 108626, 108627, 108649, 108652, 108657, 108658, 114224(869) and 109927(869)	L1
115090	Presser Bar Lifter Connecting Cable	E2
115143	Oil Pipe Guide Pin	H5
115227	Chain Cutter Knife (movable) Shaft Drive Collar with three 141087(869)	M1
115228	Chain Cutter Knife (movable) with 115240 (for agents only)	M1
115240	Chain Cutter Knife (movable) Drive Pin	M
115254	Feed Driving Arm with 350606(869) and two 141292(869)	D6
115255	Feed (back) Bar Driving Arm with two 114298(830)	D6
115256	Feed Driving Arm Pin	D7
115263	Feed (back) Bar Driving Arm 115255 with 1628(809), 17022 and 165315	D6
115292	Needle Guard (overedge needle)	G7
115293	Needle Guard (auxiliary needle) (5 mm)	F7 G7
115294	Needle Guard (auxiliary needle) (2.5 mm)	F7 G7
115295	Looper (left hand) Thread Tube (lower)	F7
115331	Chain Cutter Knife (movable) Shaft	L1
115332	Chain Cutter Knife (stationary)	M1
115333	Chain Cutter Knife (stationary) Extension	M1
115418	Treadle Extension	B2
115420	Treadle 152168 with 51723, 115418, 152171 and 67425	C2
115421	Treadle 115420 with 152153 and two 152080	C2
115465	Machine Base	A2
115466	Oil Reservoir	J6
115484	Tension Thread Guide	G1 H1
115487	Machine Frame Top Cover Closing Plate with 107044	J3
115491	Chip Chute Sleeve	C3
115492	Chip Chute	C4
115496	Knife (movable) Lever and Presser Bar (upright) Housing Cover (hinged)	H3
115503	Knife (movable) Lever and Presser Bar (upright) Housing Cover Stop Plate	G3
115510	Oil Reservoir Gasket	J7
115514	Oil Breather Plug Screw	H4
115517	Oil Filler Cap and Flow Indicator	J3
115518	Chip Chute Support Plate	C4
115519	Machine Frame Support Pin	H7 J7
115520	Presser Bar Lifting Lever (long)	C5
115523-451	Knife (movable) Lever and Presser Bar (upright) Housing Cover Hinge Bracket	F3
115534	Oil Pump Suction Pipe	K4
115536	Oil Pump Suction Filter with 114224(869)	J6
115538	Oil Pump Suction Pipe Gasket	K4
115540	Oil Filler Cap Oil Seal	J3
115541	Tension Regulating Thread Guide	H2 J2
115544	Presser Bar Lifting Lever (long) Connection Rod	C5

Part No.	Description	Grid Ref.
115545	Thread (needle) Guide Post	H2
115549	Looper (right hand) or Spreader Carrier Connecting Link Adjusting Screw Pin with 665(803) and 165489	J6
115550	Looper (right hand) or Spreader Carrier Connecting Link Adjusting Screw Pin Washer	J6
115551	Looper (right hand) or Spreader Four-Bar Linkage Mechanism, complete, Nos. 1700(809), 51720, 108021, 108118, 115549, 115550, 164068, two each 1209(830) and 132584	J6
115559	Auxiliary Needle Loop Spreader	G8
115561	Auxiliary Looper	G8
115572	Oil Pipe	H4
115588	Oil Pump, complete, Nos. 107065, 107066, 107067 and three 350719(869) (for agents only)	J4
115589	Oil Reservoir 115466 with 106401, 107071 and 107204	J7
115610	Machine Frame Top Cover assembly, Nos. 1607(809), 108014, 108864, 113180(429), 113180(430), 113180(431), 113180(624), 115484, 115545, 164157, two each 1628(809), 98188, 107090, three 107084, four each 1698(809), 107178, 107625, 113191 (888), 114117(803), 115541, 931084 and eight 2102	—
115613	Thread (Looper) Plate Cover with 109927(869)	M7
115614	Thread (Looper) Plate Cover 115613 with 1094(819), 107095, 107096 and 107097	M7
115627	Machine Frame Top Cover with 108014 and two 107090 (for agents only)	H2
115674	Knife (movable) Lever and Presser Bar (upright) Housing Cover Latch Spring Screw Lock Washer	H3
115700	Machine Frame Rotary Shaft, complete, Nos. 165404, two 98930 and five 107037	J5
115707	Chip Chute, complete, Nos. 115492, 115518, two each 9525(819) and 350719(869)	C3
115736	Auxiliary Looper Shaft Position Collar (2) with 350719(869)	F8
115739	Oil Pipe Banjo Connection	H6 J4
115740	Oil Pipe Banjo Connection Washer (fibre)	H5, H6 J4
115741	Oil Pipe Banjo Connection Retaining Screw	J4
115742	Oil Pipe Banjo Connection Retaining Screw (lower)	H6
115814	Oil Pipe 115572 with two 90100 and 115739	H4
115841	Presser Bar Lifter Operating Arm 108222 with 1654, 98188, 114287(805), 115090 and two 8905	E2
115897	Oil Return Filter (front) Pad	J7
115909	Auxiliary Looper Avoid Connecting Link with 1520(809), 107828 and 108021	E8
115968-006	Throat Plate (2.5 mm Needle Spacing 3/32 inch bight)	—
115968-008	Throat Plate (2.5 mm Needle Spacing 1/8 inch bight)	F5
115968-010	Throat Plate (2.5 mm Needle Spacing 5/32 inch bight)	—
115968-012	Throat Plate (2.5 mm Needle Spacing 3/16 inch bight)	—
115969-008	Throat Plate (5 mm Needle Spacing 1/8 inch bight)	—
115969-010	Throat Plate (5 mm Needle Spacing 5/32 inch bight)	—
115969-012	Throat Plate (5 mm Needle Spacing 3/16 inch bight)	—
115969-014	Throat Plate (5 mm Needle Spacing 7/32 inch bight)	—
115970	Feed (back) Dog (2.5 mm) Section (right)	(F6)
115971	Feed (back) Dog (5 mm) Section (left)	(F6)
115972	Feed (back) Dog (2.5 mm), complete, Nos. 1100(830), 107950 and 115970	F6
115973	Feed (back) Dog (5 mm), complete, Nos. 1100(830), 107950 and 115971	F6
115981	Knife (stationary) Wide	G6
115999	Feed (front) Dog (5 mm)	F6
117008	Thread Unwinder Thread Eyelet Retaining Circlip	(B4)
117043	Thread (Looper) Plate Cover Latch Spring Pin	M6
117082	Knife (stationary) Wide	D2
117086	Knife (movable) Narrow	D2
117098	Auxiliary Looper Avoid Driving Arm Oil Wick	E8
117152	Differential Feed Regulating Lever Return Spring	D7
125399	Cloth Plate Hinge Stud Friction Washer	E5
131695	Feed (back) Bar Connection Screw Washer	D7
132584	Looper (right hand) or Spreader Carrier Connecting Link Hinge Pin Oil Wick	J6
139026	Machine Frame Rotary Shaft Ball Bearing	L4
140219(803)	Knee Lifter Rock Shaft Lifting Bracket Set Screw	(C2)
140351(803)	Knee Lifter Rock Shaft Knee Arm Hub Clamping Screw	(C2)
140393	Operating Cable Retaining Collar Screw	B3
140416	Machine Pulley Cap Screw	M5
140510(819)	Presser Bar (swing-out) Pivot Screw	E3
140930(869)	Looper (left hand) Driving Shaft Crank Position Screw	H5
140930(869)	Looper (right hand) or Spreader Driving Shaft Crank Position Screw	J5
141004(830)	Knife (stationary) Holder Locking Screw	F7
141004(869)	Feed Eccentric (adjustable) Set Screw	C8 D8
141087(869)	Auxiliary Looper Set Screw	G8
141087(869)	Chain Cutter Knife (movable) Drive Pin Securing Screw	M1

From the Library of Diamond Knives Corp.

Part No.	Description	Grid Ref.
141087(869)	Chain Cutter Knife (movable) Shaft Drive Collar Set Screw (2)	M1
141223-002	Treadle Hinge Bracket Bolt	B3
141292(869)	Auxiliary Looper Avoid Driving Arm Hinge Stud Securing Screw	E8
141292(869)	Auxiliary Looper Avoid Eccentric Set Screw	E7
141292(869)	Auxiliary Looper Driving Eccentric Set Screw	E7
141292(869)	Differential Feed Driving Arm Stud Set Screw	C7
141292(869)	Differential Feed Regulating Lever Shaft Collar Set Screw	C7
141292(869)	Feed Bar Hinge Pin (eccentric) Collar Set Screw	E6
141292(869)	Feed Bar Hinge Pin (eccentric) Positioning Pin Set Screw	F6
141292(869)	Feed Bar Hinge Pin (eccentric) Set Screw	E6
141292(869)	Feed (back) Bar Guide Pin Securing Screw	B7
141292(869)	Feed Driving Arm Pin Securing Screw	D7
141292(869)	Feed Driving Shaft Position Collar Set Screw	C7
141292(869)	Knife (movable) Lever Hinge Pin Set Screw	G5
141292(869)	Looper (left hand) Carrier Adjusting Screw	K6
141292(869)	Looper (right hand) Carrier Set Screw	K6
141292(869)	Auxiliary Looper Shaft (Positioning) Gauge Securing Screw	E3
141292(869)	Auxiliary Looper Avoid Eccentric Set Screw	E7
141420(803)	Feed (back) Bar Connection Screw	D7
141422(833)	Knife (movable) Clamping Screw	H6
141423(819)	Knife (movable) Holder Screw	G6
141435(803)	Presser Foot Clamp (swivel) Screw	(F4)
141436(830)	Presser Foot Extension (hinged) Screw	(F4)
141441	Presser Foot Clamp (swivel) Clamp Screw	(F4)
141444(831)	Knife (stationary) Holder Screw	F7
143283	Knee Lifter Rock Shaft Knee Arm	(C2)
143284	Knee Lifter Rock Shaft Knee Arm Hub with 356(803) and 140351(803)	(C2)
143285	Knee Lifter Rock Shaft Knee Arm, complete, Nos. 2767, 143283 and 143284	(C2)
150203	Thread Unwinder Spool Rest Cushion (felt) (5)	(B4)
152080	Treadle Position Collar with 51089	C3 D3
152153	Treadle Spring	C3
152168	Treadle	C3
152171	Treadle Extension Swivel Stud	C2
161294	Screw Driver (plastic handle) (large)	A3
164004	Feed Bar Slide Block (back)	E6
164027(819)	Knife (movable) Clamp	G6
164030	Knife (movable) Holder Screw Bearing	G6
164042	Operating Cable Friction Sleeve	B2
164043	Knife (stationary) Holder Spring	G6
164053	Looper (left hand) Driving Shaft Crank Thrust Bearing	H5
164053	Looper (right hand) or Spreader Driving Shaft Crank Thrust Bearing	J5
164053	Needle Driving Shaft Bushing Thrust Washer	H5
164068	Looper (right hand) or Spreader Locking Screw Stud	J6
164091	Thread (looper, right hand) or Spreader Take-up with 164555	K6
164093	Machine Frame Rotary Shaft Ball Sleeve	—
164098	Machine Frame Rotary Shaft Oil Return and Ball Bearing Grease Retainer	L3
164100	Machine Frame Rotary Shaft Thrust Bearing	L4
164139	Presser Bar Lifting Lever Spring	F3
164141(809)	Presser Bar (swing-out) Lifting Screw Stud	F4
164144	Presser Bar (upright) Spring (alternative to 164416)	(G3)
164157	Tension (light) Spring	H1
164163	Thread (looper, right hand) or Spreader Take-up Eyelet (adjustable)	L6
164164	Thread (looper, right hand) Thread Eyelet (movable)	A4
164165	Thread (looper, right hand) or Spreader Thread Eyelet (stationary)	L7
164189	Machine Cushion (small) (2)	A2
164196	Threader (6)	A3
164351(819)	Presser Bar (swing-out) Pivot Screw Locking Plate	E4
164416	Presser Bar (upright) Spring (heavy)	G3
164449	Thread (looper, right hand) or Spreader Thread Eyelet (movable)	M7
164525	Knife (stationary) Holder Spring Stud	G6
164550	Knife (movable)	A4G4
164555	Thread (looper, right hand) or Spreader Take-up Guide Wire	L6
164727	Knee Lifter, complete, Nos. 2763, 6337, 59324, 143285, 164729, two each 2770 and 12242	C2
164729	Knee Lifter Rock Shaft Lifting Bracket Hook	(G2)
164744	Knife (stationary) Clamping Gib	G6
164745	Knife (stationary) Holder Body with two 50611(803)	F7
165135	Feed Bar Slide Block (front)	F6
165157	Oil Return Filter (front) Fastener	J7
165259	Looper (right hand) Carrier Connecting Link Adjusting Screw Pin Wick	H6
165259	Auxiliary Looper Avoid Driving Arm Hinge Pin Oil Wick	E7
165259	Feed (front) Bar Connection Oil Wick (long)	E5
165259	Auxiliary Looper Avoid Driving Arm Hinge Stud Oil Wick	E8
165259	Feed (back) Bar Connection Oil Wick (long)	D7
165260	Auxiliary Looper Avoid Driving Arm Hinge Pin Cross Oil Wick	E7

Part No.	Description	Grid Ref.
165260	Auxiliary Looper Shaft Cross Oil Wick	E7
165260	Auxiliary Looper Avoid Driving Arm Hinge Stud Cross Oil Wick	E8
165273	Auxiliary Looper Driving Connection Locating Plate	E7
165276	Auxiliary Looper Shaft with 185(806) and 82482	E7 F8
165277	Auxiliary Looper Shaft 165276 with 165278 and two 165260	F8
165278	Auxiliary Looper Shaft Oil Wick	E8
165279	Auxiliary Looper Shaft Bushing (front)	F8
165283	Looper (right hand) or Spreader Carrier Connecting Link Adjusting Screw Pin Nut	J6
165287	Cloth Plate Lock Spring	E6
165290	Cloth Plate Position Collar with two 114224(869)	E5
165291	Knife (movable) Guard (lower)	H6
165292	Cloth Plate, complete, Nos. 1700(809), 51408(832), 165287, 165514 and two 237(809)	E5
165301	Feed Bar Hinge Pin (eccentric)	E6
165303	Feed Bar Hinge Pin (eccentric) Collar with 141292(869)	E6
165306	Feed (back) Bar	E6
165307	Feed (back) Bar Connection	D7
165308	Feed (back) Bar Connection 165307 with 165259, 165310 and 165311	D7
165309	Feed (back) Bar Connection Bushing	D7
165310	Feed (back) Bar Connection Oil Wick (short)	D7
165311	Feed Bar Connection Oil Wick Retaining Pin	D7
165315	Feed (back) Bar Driving Arm Eccentric Stud	E7
165323	Feed Eccentric (adjustable) End Washer	D7
165326	Feed (front) Bar	F6
165330	Feed (front) Bar Connection Oil Wick (short)	E5
165347	Feed Driving Shaft	D6
165348	Feed Driving Shaft 165347 with 165350 and two 165349	E6
165349	Feed Driving Shaft Cross Oil Wick	D6
165349	Looper (right hand) or Spreader Carrier Connecting Link Adjusting Screw Pin Cross Oil Wick	J6
165350	Feed Driving Shaft Oil Wick	D6
165351	Feed Driving Shaft Bushing (left)	C7
165353	Knife (movable) Holder Spacer	G6
165361	Knife (stationary) Holder (adjustable), complete, Nos. 141444(831) 164745 and 165510	G6
165362	Knife (stationary) Holder (adjustable) with Gib, complete, Nos. 3146, 114032(832), 164744 and 165361	G6
165373	Machine Frame End Cover Dowel Pin	C8
165384	Machine Frame Oil Drain Plate Screen (2)	H6 H7
165392	Machine Frame Oil Splash Guard (top)	L
165395	Machine Frame Oil Drain Plate	H7
165399	Machine Frame Rotary Shaft Bearing (left)	C8
165404	Machine Frame Rotary Shaft Key	H5
165406	Machine Frame Wearing Plate	J6
165419	Presser Bar (swing-out)	E4
165421	Presser Bar (upright)	G4
165423	Presser Foot Body Guide Plate	(F4)
165424	Presser Foot Clamp (swivel) with 141441	(F4)
165429	Presser Foot Extension (hinged) Spring	(F4)
165431	Presser Foot (2.5 mm), complete, Nos. 141435 and 165424	F4
165432	Tension (auxiliary looper), complete, Nos. 418(809), 1562(809), 165433 and two 2455	L
165433	Tension (auxiliary looper) Spring	M6
165469	Presser Foot (5 mm), complete, Nos. 141435(803) and 165424	F4
165487	Knife (movable) Guard (upper)	G6
165489	Looper (right hand) or Spreader Carrier Connecting Link Adjusting Screw Pin Spring Clip	J6
165510	Knife (stationary) Holder	G6
165514	Cloth Plate	E5 F5
165519	Machine Frame Oil Drain Plate Filter (felt)	H7
175032	Differential Feed Regulating Lever Stop Screw Washer	A8
175032	Thread (looper) Plate Cover Hinge Bracket Screw Washer (2)	M8
228476	Screw Driver	A3
228661	Thread (looper) Plate Cover Stop Rubber (2)	L6
350606(869)	Auxiliary Looper Driving Arm Clamp Screw	F8
350606(869)	Feed Driving Arm Clamp Screw	D6
350647(869)	Oil Pump Body Clamping Screw	K5
350647(869)	Machine Base Mounting Screw (4)	B2
350680(869)	Looper (right hand) or Spreader Four-Bar Linkage Mechanism Stabiliser Screw	J5
350687(869)	Machine Frame End Cover Securing Screw (3)	C8
350719(869)	Auxiliary Looper Shaft Position Collar Screw	F8
350719(869)	Differential Feed Driving Arm Clamping Screw	D6
350719(869)	Differential Feed Regulating Lever Return Spring Arm Clamping Screw	D6
350719(869)	Feed (front) Bar Driving Arm Screw	D6
350719(869)	Needle Carrier Clamping Screw	G5
350719(869)	Oil Pump Cover Screw	K4
350719(869)	Chip Chute Support Plate Screw	C4

Part No.	Description	Grid Ref.
350744	Oil Reservoir Screw (6)	J8
350754(869)	Knife (movable) Lever and Presser Bar (upright) Housing Cover Hinge Bracket Screw (2)	F3
701679	Earthing Wire Screw Washer	E2
820193-002	Wrench (regular) for 1/16 inch Socket Head Screw	M2
820193-003	Wrench (regular) for 5/64 inch Socket Head Screw	A3
820193-005	Wrench (regular) for 1/8 inch Socket Head Screw	A3
820193-007	Wrench (regular) for 3/16 inch Socket Head Screw	A3
820193-009	Wrench (long) for 3/32 inch Socket Head Screw	A3
820193-010	Wrench (regular) for 7/32 inch Socket Head Screw	A3
931084	Tension Screw Stud Lock Washer	H2
Cat. 1431	Needle, size 12	G6
Cat. 8508	Needle, size 12	G6